

# INSTALLATION INSTRUCTIONS

## Pulse Energy Meter

### EM-PULSE and Current/Voltage Transducers

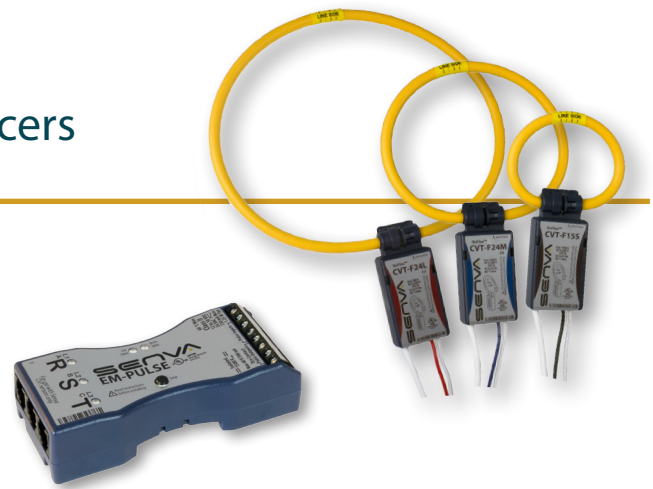

The EM-PULSE is a three channel meter, capable of monitoring single-phase, two-phase and three-phase systems, as well as 3 independent single-phase systems with one meter. The EM-PULSE meter offers 2 pulse outputs and 2 pulse inputs to maintain flexibility during installation and operation. The EM-PULSE is compatible with all sizes of current/voltage transducers (CVTs). With the meter's AutoScale feature, the pulse scale is set according to the CVT amperage, removing the need for manual configuration.

Each CVT is independently calibrated to measure and digitally communicate power values with the meter. The CVT's flexible rogowski coil makes installations less burdensome. To maintain high accuracy and flexibility for multiple channel installs, high voltage connections are made directly into each CVT. Each CVT is rated for installations ranging from 90 to 600V.

### **DANGER**

#### **HAZARD OF ELECTRIC SHOCK, EXPLOSION, OR ARC FLASH**

**Failure to follow these instructions may cause serious injury or death**

- Read, understand and follow the instructions before installing this product.
- The high voltage CVTs of this product must be mounted inside a suitable fire and electrical enclosure. Follow safe electrical work practices. See NFPA 70E in the USA, or applicable local codes.
- This equipment must only be installed and serviced by qualified electrical personnel having the skills and knowledge related to the construction and operation of this electrical equipment and installation, and has received safety training to recognize and avoid the hazards involved. NEC Article 100.
- Do not use this product for life or safety applications.
- Do not install this product in hazardous or classified locations.
- Product may use multiple voltage/power sources. Disconnect ALL sources before servicing.
- Use a properly rated voltage sensing device to confirm that power is off. DO NOT depend on this product for voltage indication.
- Replace all doors, covers and protective devices before powering the equipment.
- The installer is responsible for conformance to all applicable codes.

### **WARNING**

**Failure to follow these instructions may cause injury, death or equipment damage.**

- The EM-RS485 and CVT sensors are designed to be used as a system. DO NOT connect anything other than a Senva CVT sensor to the RJ-11 jacks on the meter base.
- If product is used in a manner not specified by the manufacturer, the protection provided by the product may be impaired. No responsibility is assumed by the manufacturer for any consequences arising out of the use of this material.

### **WARRANTY DISCLAIMER**

DO NOT modify the length of the CVT Data Communication Cable. Field modifications to the CVT Data Communication Cable will void factory warranty.

#### LET'S GET STARTED!

##### **Product Descriptions (page 2)**

- EM-PULSE product diagram
- Current/Voltage Transducer (CVT) diagram

##### **Mounting (page 2)**

- Versatile mounting options for EM-PULSE
- Recommended mounting for maximum CVT accuracy

##### **Wiring (page 3)**

- Typical single-phase and three-phase systems
- Output wiring options
- Input wiring options

##### **Normal Operation Mode (page 4)**

- LED indicators for Normal, Warning, and Error conditions

##### **Diagnostics Mode (page 4)**

- Diagnostic Mode and Diagnostic Codes

##### **Default Settings (page 5)**

##### **Configuration Settings (pages 5-6)**

- Pulse Scale
- Pulse/Alarm Options
- Energy Output Types
- Balanced Load Multiplier
- PowerPrint Power Quality Alarm

##### **View and Edit Settings (pages 7-8)**

- View Settings Mode
- Edit Settings Mode

##### **Specifications (page 9)**



# ① Description

## EM-PULSE

The EM-PULSE is a 3 channel pulse meter with two pulse inputs and two pulse outputs. The EM-PULSE supports the use of all Senva Current Voltage Transducers (CVTs), interchangeably. The EM-PULSE meter base is a class 2 low voltage device for mounting flexibility. See *Section 9 - Specifications* for recommended conductor gauge and terminal tightening torque.

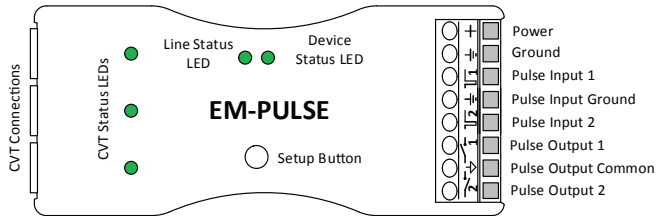

## Current Voltage Transducer (CVT)

The Current/Voltage Transducer (CVT) senses both current and voltage. Each CVT is independently calibrated and uses digital communication with the meter for superior noise immunity and accuracy. Each CVT will automatically configure with the meter during installation, eliminating the need for manual configuration.

DO NOT modify the length of the CVT Data Communication Cable. Field modifications to the CVT Data Communication Cable will void factory warranty.

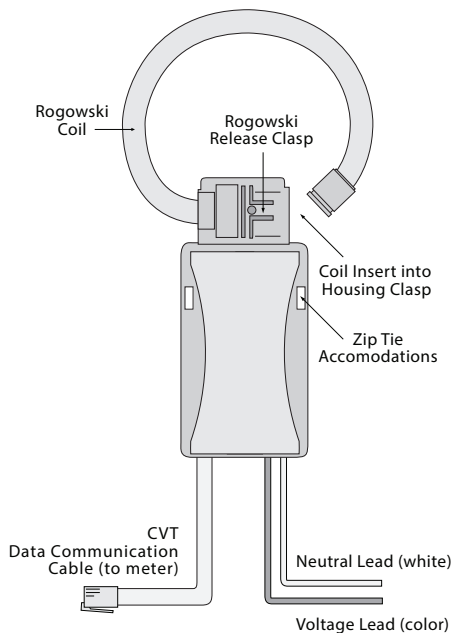

Opening the CVT Clasp

# ② Mounting

## Meter Mounting Options

The EM-PULSE features four mounting options for convenience: rare-earth magnets, mounting tabs, horizontal DIN rail and vertical DIN rail.

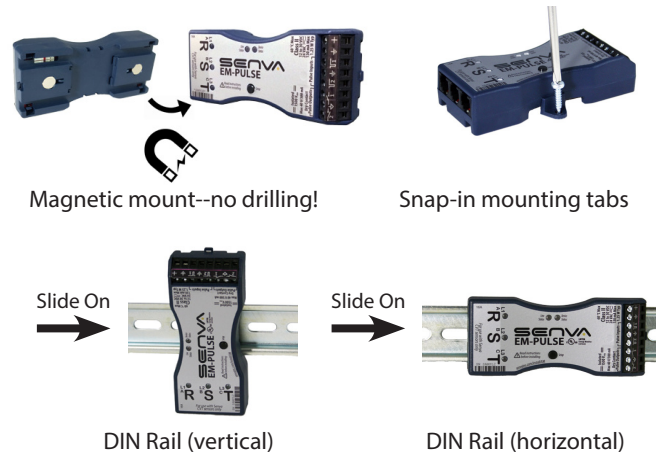

## Current Voltage Transducer (CVT) Mounting

The CVTs have a preferred mounting angle relative to the conductor that will help maintain maximum accuracy. See below for instructions.

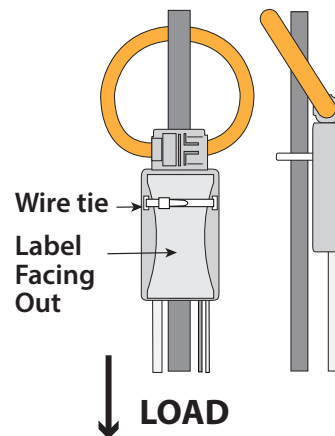

ⓘ Ensure orientation of CVT to load is as shown.

## Installation Environment

This product is intended for environments which control conductive pollution and the possibility of condensation or high humidity (Pollution level 2). High voltage components shall be mounted in an appropriate electrical enclosure. Meter base is class 2 device.

CVTs may not be installed in a panel where they exceed 75% of the wiring space of any cross-sectional area within the panel. Meter shall be enclosed in a certified enclosure.

### ③ Wiring

Provide a disconnect device to disconnect the meter from the supply source. In the US and Canada, disconnecting fuse holders or circuit breakers can be used. Place this device in close proximity to the meter and within easy reach of the operator, and mark it as the disconnecting device. The disconnecting device shall meet the relevant requirements of IEC 60947-1 and IEC 60947-3 and shall be suitable for the application. Provide overcurrent protection and disconnecting device for supply conductors with approved current limiting devices suitable for protecting the wiring.

#### TYPICAL 3Ø WIRING 85 to 600VAC

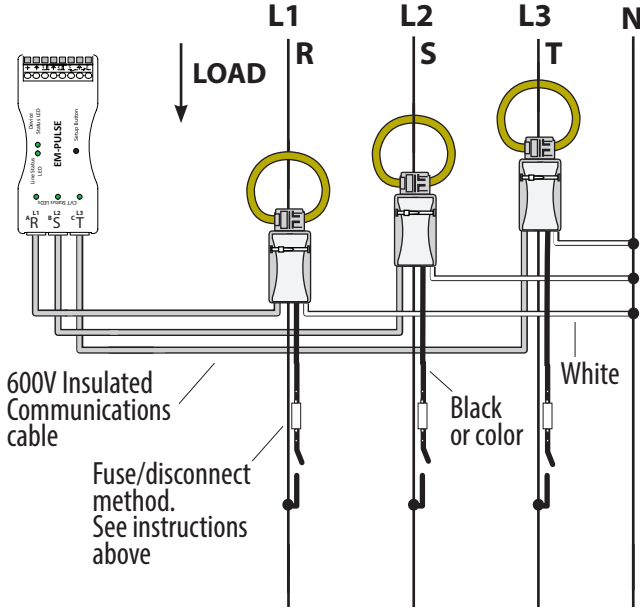

#### TYPICAL 1Ø WIRING

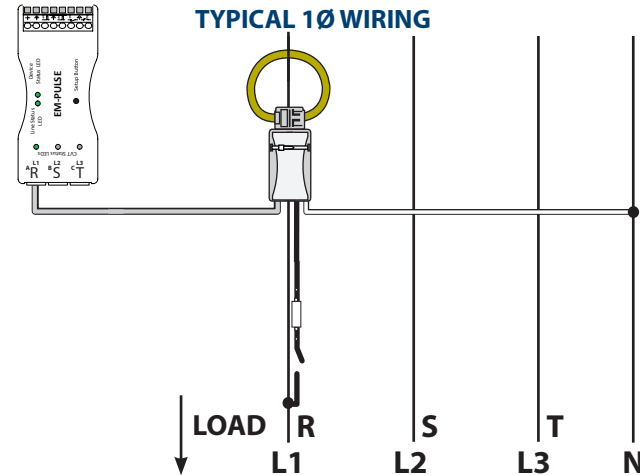

For 3Ø Δ connections with no neutral, cap each CVT's neutral (white) wire.

#### METER BASE WIRING

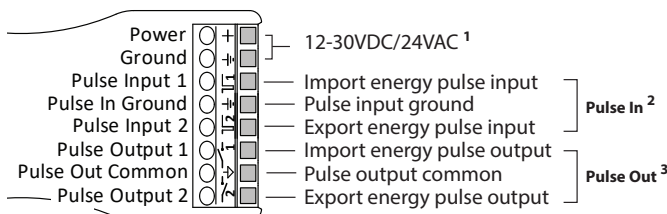

<sup>1</sup> One side of transformer secondary is connected to signal common. Dedicated transformer is recommended.

<sup>2</sup> Pulse inputs accept energy at the same pulse scale as the meter output pulse scale setting. 1 pulse in = 1 pulse out.

<sup>3</sup> Open collector, 75mA max, 40V max.

#### PULSE OUTPUT WIRING OPTIONS

The four diagrams below detail wiring for common installation configurations.

##### Net Import and Export Energy

Separate import and export pulses to track positive and negative energy:

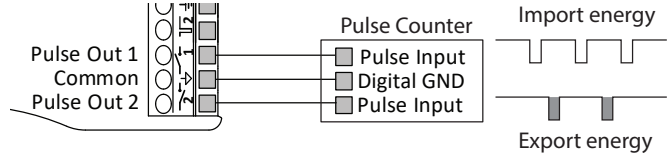

##### Import Energy Only

Track only import energy. Could also be inversely wired to track only export energy by wiring the pulse input to output 2:

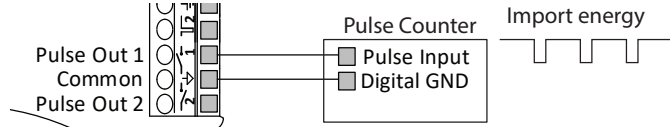

##### Total Import and Export Energy

For total (import and export) energy, jumper output 1 and output 2 together (useful in the case that one or more of the CVTs were installed in the incorrect orientation to load, or the controller has only one pulse counter available):

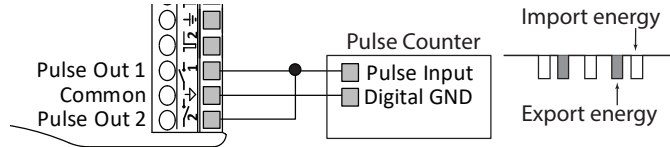

##### Total Energy (Import and Export) and Alarm

The EM-PULSE has an optional alarm mode. If the alarm is manually configured on, the meter will combine the total import and export energy through output 1. Output 2 will be a normally open alarm. See Section 7.2 - Configuration Settings for further details on Pulse/Alarm Options:

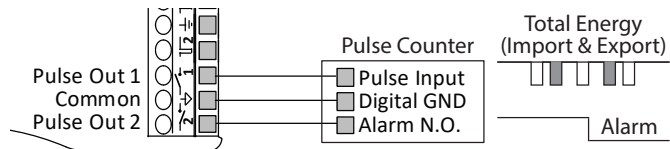

#### DAISY CHAIN WIRING EXAMPLE

The EM-PULSE is capable of accepting pulse inputs from another meter. It will aggregate the pulses and report them. The meters must all be set with the same pulse scale.

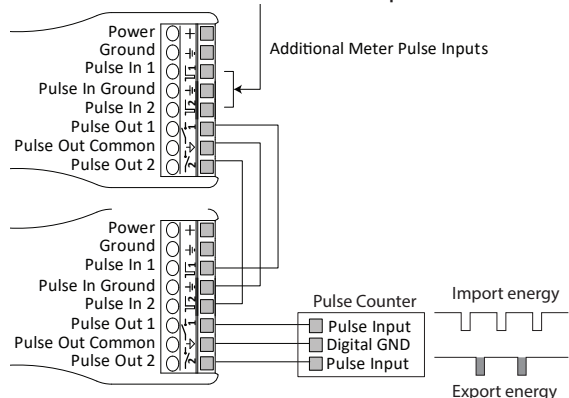

⚠ Do not exceed the maximum pulse rate of each meter when multiple meters are aggregated.



## ④ Normal Operation Mode

When powered, the EM-PULSE meter will start up in Normal Operation Mode. The meter will always return to Normal Operation Mode after 60 seconds of inactivity in any of the setting menus.

In Normal Operation, there are 3 sets of LEDs that provide status indications:

- ① CVT Status LEDs
- ② Line Status LED
- ③ Device Status LED

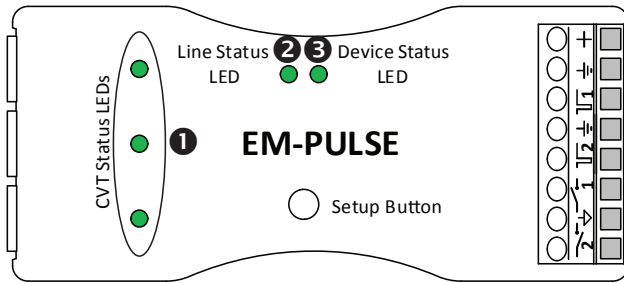

The color of each LED will indicate conditions of the system:

- Green = Normal
- Yellow = Warning: See Diagnostics Mode
- Red = Error: See Diagnostics Mode

If one or more LEDs is blinking:

- CVT LEDs ① will blink when no load is present
- Line LED ② will blink when a pulse is sent
- Device LED ③ will blink when a non-factory default setting is present

If LEDs ①②③ are green ● (blinking or solid), proceed to *Section 6 - Default Settings*, to finalize installation.

If any of the LEDs ①②③ are yellow ● or red ● (blinking or solid) proceed to *Section 5 - Diagnostics*.

## ⑤ Diagnostics Mode

In Normal Operation Mode, LEDs ①②③ indicate conditions of the system using colors green ●, yellow ● and red ●. The Diagnostics Mode allows users to view underlying conditions that are causing one or more of the LEDs ①②③ to appear yellow ● or red ●. Utilize the *Diagnostic Mode Navigation* along with *Table 1. Diagnostic Codes* to determine underlying conditions.

If all LEDs are green ●, proceed to *Section 6 - Default Settings*.

### Diagnostic Mode Navigation

In Diagnostic Mode, the 3 sets of LEDs ①②③ provide status indication. The Setup Button ④ is used for mode selection and navigation:

- ① CVT Status LEDs
- ② Line Status LED
- ③ Device Status LED
- ④ Setup Button

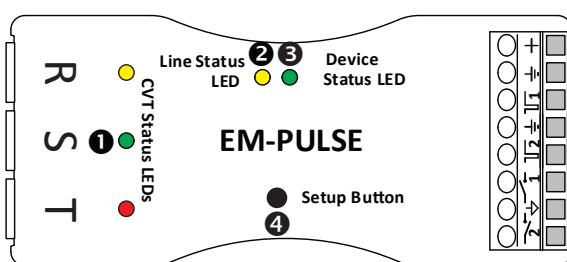

Diagnostic Mode is only available if any LEDs ①②③ display yellow ● or red ● in Normal Operation Mode.

1. To enter Diagnostic Mode, press **P** the Setup Button ④. The first diagnostic code will be displayed on one of the LEDs, repeating every three seconds.
2. Match the LED location, color, and blink pattern to a condition in Table 1. Diagnostic Codes.

*Note: For CVT Status, the diagnostic blink pattern will apply to a specific channel (R,S or T) on which the condition is present.*

3. Press **P** Setup Button ④ to view next code and repeat Step 2 to diagnose condition.
4. Continue to diagnose conditions until there are no new codes to diagnose (codes are repeated).
5. To exit Diagnostic Mode, hold Setup Button ④ until the Device LED ③ lights up (approximately 2 second **2s** hold) and release. After 60 seconds of inactivity, the device will revert back to Normal Operation Mode.

### Diagnostic Mode Navigation Flowchart

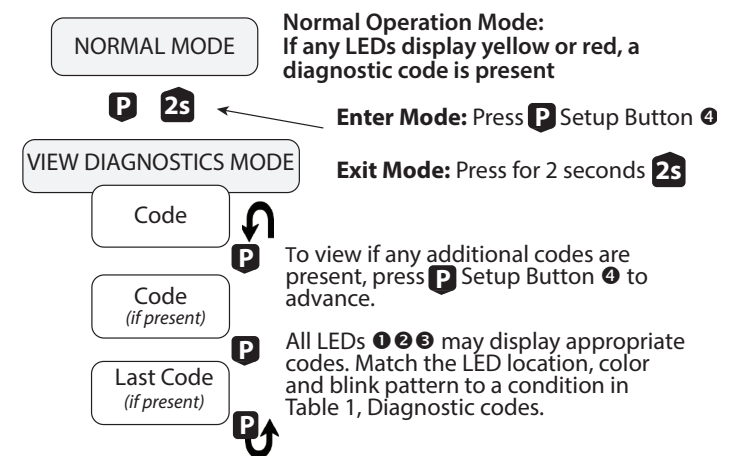

Table 1. Diagnostic Codes		
① CVT LEDs	Indication	Corrective Action
	Negative power	Verify CVT orientation toward load
	Phase Loss	Check phase voltage and current
	Low power factor	If not low PF, ensure voltage legs match with CVTs
	Frequency out of range	Frequency is below 38Hz or above 150Hz
	Over voltage	Ensure system voltage does not exceed 600VAC
	Over current	Replace with a larger amperage rated CVT

② Line LED	Indication	Corrective Action
	Mismatched voltages on power sensors	Ensure desired voltages are being monitored
	Not a three phase system (not 120 degree voltage angle)	Ensure desired voltages are being monitored
	Reversed Phase Order	Swap any two CVT meter inputs if not intentional
	Pulse Overload	Select larger pulse scale

③ Device LED	Indication	Corrective Action
	Low supply voltage	Increase meter supply voltage
	Temperature warning	Relocate meter to suitable environment

If code is not shown in table above, please contact Senva technical support: support@senvainc.com or (866) 660-8864

## ⑥ Default Settings



The EM-PULSE installs with minimal user intervention.

*If LEDs are green and you are happy with default factory settings below, your installation is complete!*

Each meter has five factory default settings. Review the factory default settings and their definitions below.

Setting	Factory Default
1. Pulse Scale	AutoScale Enabled
2. Pulse/Alarm Options	Fast Pulses (30ms), KY Mode
3. Energy Output Type	Real 'True' Power (P)
4. Balanced Load Multiplier	Off/Disabled
5. Powerprint Options	Off/Disabled

### Default Setting 1. Pulse Scale

AutoScale is the default factory setting. With AutoScale, pulse scale is automatically set based on the CVT amperage rating as follows:

CVT Rated Amps	Default Pulse Scale
5-50A	1 Wh/pulse
51-500A	10 Wh/pulse
501-5000A	100 Wh/pulse
5000+A	1 kWh/pulse

Check CVT amperage rating to determine the pulse scale. For alternative pulse scale settings, see *Section 7.1 - Pulse Scale*.

### Default Setting 2. Pulse/Alarm Options

Fast Pulses (30ms), KY Mode is the default factory setting. Fast pulses corresponds to a pulse width of 30 milliseconds. In KY Mode pulses are the representative units and each pulse output is independent. For alternative pulse widths, KYZ Mode, or Alarm options see *Section 7.2 - Pulse/Alarm Options*.

### Default Setting 3. Energy Output Type

Total Real 'Active' Energy (P) is the default factory setting. This is the metric that utility companies typically use for billing.

For alternative Energy Output Types, see *Section 7.3 - Energy Output Type*.

### Default Setting 4. Balanced Load Multiplier

The Balanced Load Multiplier is disabled in the default factory settings. For options on balanced load multipliers see *Section 7.4 - Balanced Load Multiplier*.

### Default Setting 5. PowerPrint

PowerPrint is disabled in the default factory settings. For details on how to utilize PowerPrint see *Section 7.5 - PowerPrint*.

### To Restore Factory Default Settings

*Caution: Restoring factory default settings will revert device to settings listed above. Any manual configurations will be reset.*

1. Hold setup button down until all LEDs blink red (approximately 30 seconds) and release.
2. Momentarily press the setup button again within 5 seconds of the first release.
3. The LEDs will stop blinking and remain solid red for about 1 second.
4. Meter is now reset to factory default settings.

## ⑦ Configuration Settings

The EM-PULSE meter allows for manual configuration of the following settings:

1. Pulse Scale
2. Pulse/Alarm Options
3. Energy Output Type
4. Balanced Load Multiplier
5. Powerprint

Each setting has factory default, which can be found in *Section 6 - Default Settings*.

This section will further define each setting and detail alternative settings that can be manually configured utilizing *Section 8 - View and Edit Settings*.

### Setting 1. Pulse Scale

There are 8 Pulse Scale options on the EM-PULSE meter: AutoScale operation based on CVT rated amperage, user selectable pulse scales, or LiveScale based on current energy.

Setting	Function
AutoScale <sup>1</sup> - Default	Pulse scale set based on CVT amperage rating
0.01 Wh/pulse	User Selectable pulse scales
0.1 Wh/pulse	
1 Wh/pulse	
10 Wh/pulse	
100 Wh/pulse	
1000 Wh/pulse	
LiveScale <sup>2</sup>	Set based on current energy being monitored

<sup>1</sup>AutoScale pulse scale is selected based on the largest CVT size installed. This is the factory default setting for the meter. See *Section 6.1 - Pulse Scale* for usage of AutoScale pulse scaling.

<sup>2</sup>LiveScale takes a sample of energy currently being monitored and calculates the most appropriate pulse scale after 10 seconds of sampling. LiveScale should be initiated when panel is fully loaded. This ensures that the automatically chosen pulse is appropriate to the monitored load while avoiding the pulse overload warning condition.

### Setting 2. Pulse/Alarm Options

Pulse/Alarm Options allow for setting different pulse types (KY vs KYZ) and alarm outputs for alerts of phase loss or changes from a saved PowerPrint (*Setting 5. PowerPrint*). There are 6 Pulse/Alarm Options on the EM-PULSE meter:

Setting	Pulse/Alarm Function
Fast pulses, KY mode - Default	30ms pulse width, KY mode
Slow pulses, KY Mode	1s pulse width, KY mode
Fast pulses, Alarm mode	30ms pulse width, alarm output enabled, KY mode
Slow pulses, Alarm mode	1s pulse width, alarm output enabled, KY mode
Fast pulses, KYZ mode	30ms pulse width, KYZ mode
Slow pulses, KYZ mode	1s pulse width, KYZ mode

*Fast Pulses:* Pulse width of 30 milliseconds

*Slow Pulses:* Pulse width of 1 second

*KY Mode:* Each pulse (2 edges) represents 1 unit of energy. The 2 pulse outputs are independent.

*KYZ Mode:* Each edge represents 1 unit of energy. The 2 pulse outputs form a complementary pair.



**Alarm Mode:** Output 2 provides a normally open alarm output. The default alarm is for phase loss of one or more channels in a multi-phase installation. Alarm mode will also convert output 1 to the total import and export energy sensed by the meter. See *Section 3 - Wiring: Pulse Output Wiring Options*.

**PowerPrint Alarm Mode:** When PowerPrint is turned on Output 2 provides a normally open alarm output for all PowerPrint alarm conditions. See *Setting 5. PowerPrint* below for all alarm conditions. Alarm mode will also convert output 1 to the total import and export energy sensed by the meter. See *Section 3 - Wiring: Pulse Output Wiring Options*.

### Setting 3. Energy Output Type

There are 4 Energy Output Type settings in the EM-PULSE meter: Total Real 'Active' Energy, Net Real 'Active' Energy, Reactive Energy, and Apparent Energy.

Setting	Energy Units
Total Real 'Active' Energy <sup>1</sup> (P) - default	Measured in watts (Wh or kWh) Meter will output total import and export energy of all CVT channels
Net Real 'Active' Energy <sup>2</sup> (P <sub>net</sub> )	Measured in watts (Wh or kWh) Meter will output net energy
Reactive Energy (Q)	Measured in volt-amperes reactive (VARh or kVARh)
Apparent Energy (S)	Measured in volt-amperes (VAh or kVAh)

<sup>1</sup>Total Real 'Active' Energy outputs both import and export pulses as the energy is accumulated by the meter.

<sup>2</sup>Net Real 'Active' Energy sums the channels internally before outputting, so import and export energy will cancel, resulting in the net energy output.

### Setting 4. Balanced Load Multiplier

The Balanced Load Multiplier is utilized so that one CVT can extrapolate power of a balanced load (e.g. motor) without actually monitoring all 3 phases. The multiplier can be applied to one or more CVT channels, meaning the EM-PULSE can monitor up to three motors with one meter:

Setting	Balanced Load Multiplier Function
Disable all balanced load multipliers - Default	All balanced load multipliers are disabled
Enable R balanced load multiplier	Output for R channel = 3X power measurement
Enable S balanced load multiplier	Output for S channel = 3X power measurement
Enable RS balanced load multipliers	Output for R & S channels = 3X power measurement
Enable T balanced load multiplier	Output for T channel = 3X power measurement
Enable RT balanced load multipliers	Output for R & T channels = 3X power measurement
Enable ST balanced load multipliers	Output for S & T channels = 3X power measurement
Enable RST balanced load multipliers	Output for all channels = 3X power measurement

### Setting 5. PowerPrint

PowerPrint is a power quality alarm that enables the meter to learn and save characteristics of the system being monitored. Based on recorded values, the meter can provide alarm conditions and allow user to evaluate system status at a later time. This is an optional feature, but as PowerPrint is turned on, the meter identifies each CVT connection and saves settings on the following parameters:

1. Which channels have a CVT connected
2. Amperage rating and internal serial number of each CVT
3. System voltage
4. System frequency
5. Phase voltage angle

PowerPrint can only learn and save characteristics for channels with a properly installed CVT. If the CVT is displaying a warning or error condition during Normal Operation, take the corrective action to resolve the installation error prior to enabling PowerPrint.

When PowerPrint is enabled, it will identify which channels are active (have properly installed CVTs) and apply the learn and save characteristics to those channels:

Setting	PowerPrint Function
PowerPrint off - default	PowerPrint is disabled
PowerPrint on Channel R	PowerPrint enabled for all channels with a properly installed CVT.  <i>PowerPrint should not be saved if any channels display an error condition (red LED) during Normal Operation (See Section 4 - Normal Operation Mode).</i>
PowerPrint on Channel S	
PowerPrint on Channels RT	
PowerPrint on Channel T	
PowerPrint on Channel RT	
PowerPrint on Channel ST	
PowerPrint on Channel RST	

Once PowerPrint has been turned on and the system characteristics have been saved, the alarm conditions below will be displayed on the meter LEDs as a warning or error during Normal Operation (See *Section 4 - Normal Operation Mode*):

Alarm Condition	Parameter
Missing sensor	CVT missing on one or more channels
Unexpected sensor	CVT identity does not match original CVT saved in Powerprint
Brown out voltage	Voltage < 10% from saved voltage
Surge voltage	Voltage > 10% from saved voltage
Frequency drift <sup>1</sup>	Frequency not within +/-0.2Hz from saved frequency
Phase drift	Phase voltage angle variance > +/-30° from saved angle

<sup>1</sup>PowerPrint will not monitor frequency variance if system frequency is not 50 or 60Hz when PowerPrint is initiated.

**PowerPrint Diagnostic Codes:** The following alarm codes are to be used in addition to *Table 1. Diagnostic Codes* in *Section 5 - Diagnostics Mode* with PowerPrint On:

Table 2. PowerPrint Diagnostic Codes		
CVT LEDs	Indication	Corrective Action
	Missing sensor	Reconnect original CVT to meter
	Unexpected sensor	Reconnect original CVT to meter
	Brown out voltage	Verify system voltage
	Surge voltage	Verify system voltage
Line LED	Indication	Corrective Action
	Frequency drift	Verify system voltage
	Phase drift	Verify system voltage

**PowerPrint Alarm Mode:** In addition to the LED indicators above, the PowerPrint can also alert via an output alarm when a PowerPrint warning condition is present. This requires the user to select Alarm Mode in *Setting 2. Pulse/Alarm Options*. With PowerPrint On and Alarm Mode selected, the meter will now display warning conditions on the LEDs and provide an alarm output to the controller.

## ⑧ View and Edit Settings

To view and edit the settings on the EM-PULSE meter, proceed through the steps below for manual configuration with the setup button and LEDs.

### View Settings Mode Flowchart

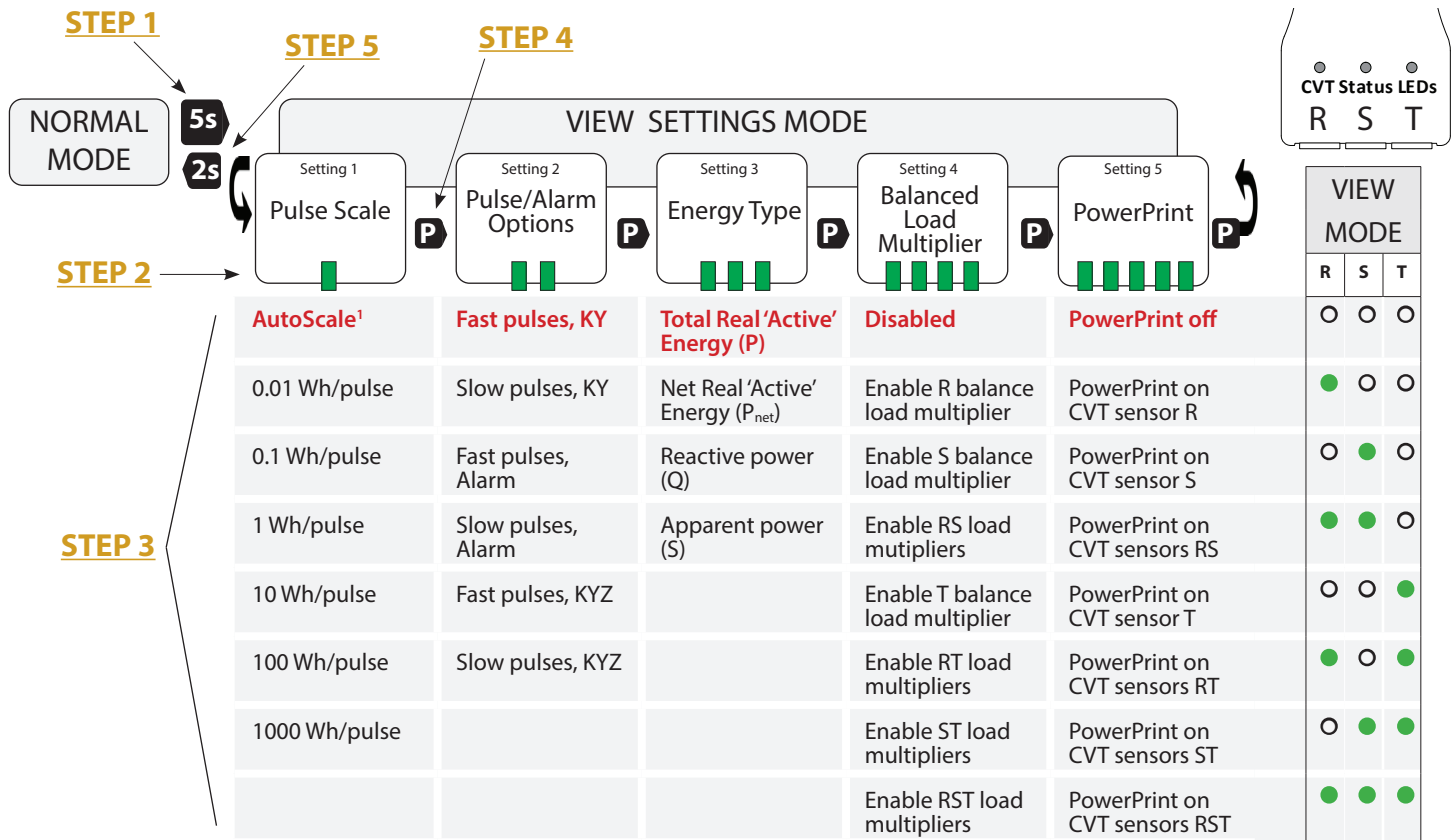

Red denotes default settings.

<sup>1</sup> AutoScale only displayed in Edit Settings Mode. In View Settings Mode, the maximum pulse scale defined by installed CVT size (see Section 6 - Default Settings) will be displayed, consistent with internal operations.

### VIEW SETTINGS MODE

In View Settings Mode, Settings 1-5 will be accessible to view and confirm. The Line LED ② will indicate which Setting Group is being viewed with green ● blinks and the CVT LEDs ① will indicate the current setting in green ●. (Device will timeout and resume Normal Operation Mode after 60 seconds of no activity)

Use the following diagram and the View Settings Mode Flowchart to assist in working through Steps 1-5 to navigate the View Settings Mode in the EM-PULSE meter:

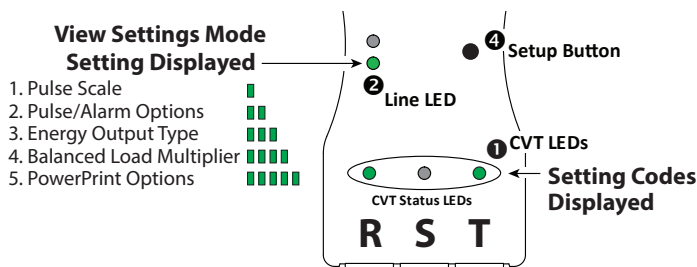

#### STEP 1 Enter View Settings Mode

From Normal Operation Mode, press and hold Setup Button ④ until Line LED ② rapidly blinks green ● (approximately 5 second 5s hold). Release and meter is in View Settings Mode.

#### STEP 2 Identify Function Group

Line LED ② will blink green ● 1 to 5 times, repeating every 3 seconds, to indicate which Setting Group is being displayed in View Settings Mode. The column below each setting indicates all setting options.

#### STEP 3 Identify Current Setting

Match the CVT LED ① pattern on the meter to one of the options in the View Codes column to the far right. (The corresponding setting is listed in the same row under each Setting Group)

#### STEP 4 Advancing Through Function Groups

Press P the Setup Button ④. Line LED ② will blink green ● 1 to 5 times, repeating every 3 seconds, to indicate which Setting Group is being displayed.

#### STEP 5 To Exit View Settings Mode

Press and hold Setup Button ④ until Line LED ② rapidly blinks green ● (approximately 2 second 2s hold). Release to resume Normal Operation Mode. (Device will timeout and resume Normal Operation Mode after 60 seconds of no activity)

## View/Edit Settings Mode Flowchart

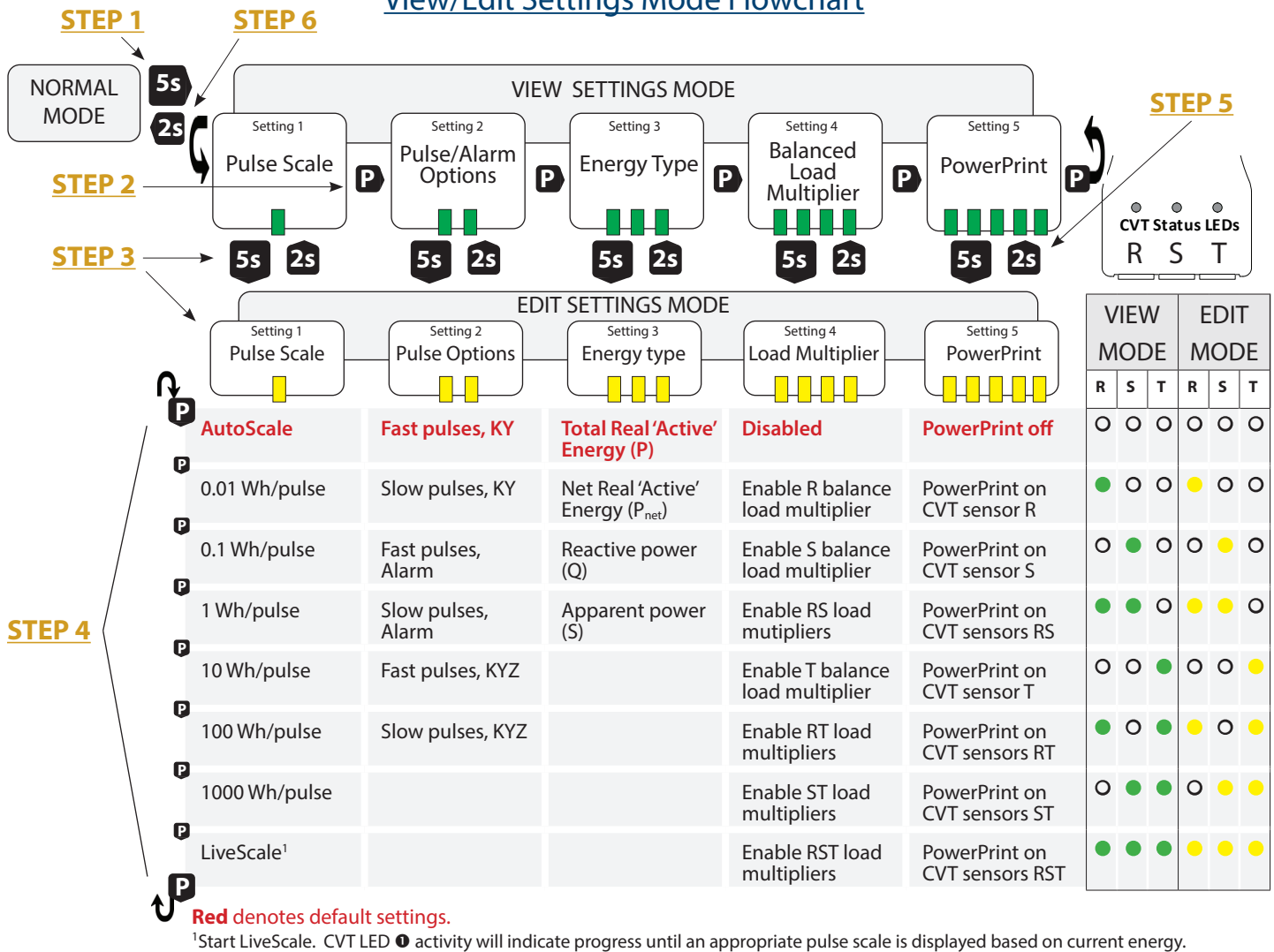

### EDIT SETTINGS MODE

In Edit Settings Mode, Setting Groups 1-5 can be modified. The Line LED 2 will indicate which Setting Group is being viewed with yellow ● blinks and the CVT LEDs 1 will indicate the current setting in yellow ●.

Use the following diagram in conjunction with the View Settings section to assist in working through Steps 1-6 to navigate the Edit Settings Mode in the EM-PULSE meter:

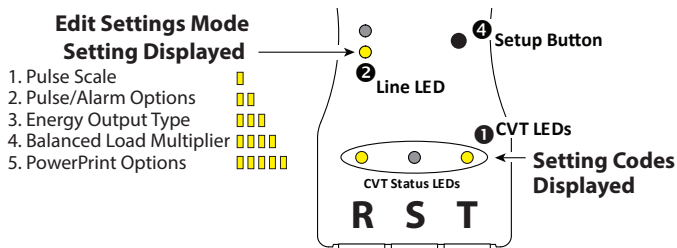

#### STEP 1 Enter View Settings Mode

Enter View Settings Mode from Normal Operation Mode. (Press and hold Setup Button 4 until Line LED 2 rapidly blinks green - approximately 5 second 5s hold)

#### STEP 2 Setting Group Identification

Press P Setup Button 4 until Setting Group that requires a setting change is displayed on the Line LED 2 in green ●.

#### STEP 3 Enter Edit Settings Mode

Press and hold Setup Button 4 until Line LED 2 appears solid yellow ● (approximately 5 second 5s hold). Release and meter is in Edit Settings Mode. (Confirm the Line LED 2 is blinking yellow ● 1 to 5 times, corresponding with the Setting Group you want to edit)

#### STEP 4 Edit Setting

The current setting will be displayed on the CVT LEDs 1 in yellow ● (representing Edit Mode). Press P the Setup Button 4 to match the CVT LED 1 pattern on the meter to one of the options in the Edit Codes column to the far right. (The corresponding setting is listed in the same row under each Setting Group)

#### STEP 5 Save Selected Setting

With the desired setting displayed on the CVT LEDs 1 in yellow ●, press and hold the Setup Button 4 until the Line LED 2 rapidly blinks green ● (approximately 2 second 2s hold). Release and meter returns to View Settings Mode with new setting saved.

#### STEP 6 Exit/Resume Normal Operation Mode

From View Settings Mode, exit back to Normal Operation Mode (press and hold Setup Button 4 until Line LED 2 rapidly blinks green ●) or repeat actions from Step 2 to edit additional settings. (Device will resume Normal Operation Mode after 60 seconds of no activity)



## ⑨ Specifications

Power Supply Input		12-30VDC/24VAC <sup>(1)</sup> , 1.5W Max, 100mA Max
Pulse Outputs	Dual Outputs	Import & Export Energy Outputs
	Type	Solid state dry contact
	Specifications	N.O., 300mA max, 40V max
	Pulse scaling	0.01, 0.1, 1, 10, 100, 1k Wh/Pulse
Wiring Requirements	Conductor gage	14-26 AWG
	Terminal torque rating	0.4 ft-lb (0.55 N-m)
Pulse Inputs	Input Rating	3.5 +/- 0.5VDC, short circuit current is 10mA max
	Pulse Rate	50 Hz max
	Pulse Active	<100 ohms
	Pulse Undefined	100-1000 ohms
	Pulse Idle	>1000 ohms
Service Types	Configurations	1Ph, 2Ph, 3Ph Wye (4-Wire), 3Ph Delta (3-Wire)
	Voltages	90VL-N through 600VL-L
	Frequency	45-65 Hz
Performance	Accuracy	<1% for V, A, kW, kVAR, kVA, PF
Current/Voltage Transducer™	Small Rope Circumference	9"
	Medium Rope Circumference	15"
	Large Rope Circumference	24"
	Grande Rope Circumference	36"
	300A Operating Range <sup>(2)</sup>	+/-1% 30-300A (+/-3% >10A)
	800A Operating Range <sup>(2)</sup>	+/-1% 30-800A (+/-3% >10A)
	1500A Operating Range <sup>(2)</sup>	+/-1% 30-1500A (+/-3% >10A)
2400A Operating Range <sup>(2)</sup>	+/-1% 50-2400A (+/-3% >15A)	
6000A Operating Range <sup>(2)</sup>	+/-1% 120-6000A (+/-3% >40A)	
Operating Environment	Temperature	-4 to 140F (-20 to 60C)
	Humidity	0-95% non-condensing
Meter Enclosure	Material	Polycarbonate/ABS
	Dimensions	4.1"h x 1.8"w x 0.9"d
CVT™ Enclosure	Material	Polycarbonate/ABS
	Enclosure Dimensions	3.5"h x 1.6"w x 0.8"d

(1) One side of transformer secondary is connected to signal common. Dedicated transformer is recommended.

(2) CVT™ Accuracy based on reading, not full scale.